

INTELLIGENT CONTROLS



**INSTALLATION AND  
PROGRAMMING MANUAL  
FOR MODEL**

**1250B**

**PROGRAMMABLE POSITION MONITOR**

**Solid State Synchro Indicator for Synchro Transmitter**

**(For use with firmware revision 4.04 or higher)**

**000-1077 Rev. J**

# TABLE OF CONTENTS

<b>Section:</b>	<b>Page:</b>
List of Figures.....	3
List of Tables.....	3
Introduction.....	4
1.0 Installation.....	4 - 7
2.0 Programming.....	8 – 20
2.1 Serial Programming.....	11
3.0 Options.....	21 - 31
3.1 Analog Output.....	21
3.2 Input Isolation.....	22
3.3 High / Low Relay Limits.....	22
3.4 Serial RS-232.....	23
3.5 Serial RS-485 MODBUS.....	24
4 Field Calibration and Test.....	32 - 33
5 Error Codes.....	34
6 Specifications.....	35

FRANKLIN GRID SOLUTIONS, LLC  
PO Box 638  
Saco, Maine 04072 USA

Sales & Customer Service: 800-225-9787  
Technical Service 207-571-1202  
Web Site: [www.franklingrid.com](http://www.franklingrid.com) E-mail: [sales@franklingrid.com](mailto:sales@franklingrid.com)

This manual applies to all INCON model 1250B monitors with firmware revision 4.04 or higher.

Copyright 2000, 2001,2002, 2003, 2008, 2017, Intelligent Controls, Inc. All rights reserved

# LIST OF FIGURES

<b>Figure:</b>	<b>Page:</b>
1.1 Mechanical Dimensions .....	5
1.2 Field Wiring Diagram .....	5
1.3 Field Wiring Diagram with 4-20mA Option .....	5
1.4 Analog Configuration Switches and Trim Pots .....	7
2.1 Simplified Programming Flowchart .....	8
2.2 Linear Scaling Mode Analog Output .....	15
2.3 Non-Linear Scaling Mode Analog Output .....	16
2.4 Base 1 Uni-Polar Mode Analog Output .....	17
2.5 Base 0 Uni-Polar Mode Analog Output .....	18
2.6 Bi-Polar Mode Analog Output .....	19
3.1 Relay Field Wiring Diagram .....	22
4.1 Analog Output Adjustment Pots .....	32

# LIST OF TABLES

<b>Table:</b>	<b>Page:</b>
1.1 Terminal Functions .....	6
1.2 DIP Switch Functions .....	6
1.3 Digital Communication Connector Pin-Out .....	6
1.4 Analog Output Switch Positions .....	7
2.1 Numeric and Alpha-numeric Menu Items .....	9-10
2.2 Serial Programming Commands .....	11-12
3.1 Analog Output Load Limits .....	21
3.2 Wiring: 9-Pin Serial Connector Pin-Out .....	24
3.3 Read Registers Command Format .....	25
3.4 Read Registers Response Format .....	25
3.5 Write Registers Command Format .....	26
3.6 Write Registers Response Format .....	26
3.7 Error Exception Response Format .....	26
3.8 RS-485 MODBUS Register Definitions .....	28-30
5.1 Error Codes .....	36

## INTRODUCTION

The Model 1250B Programmable Position Monitor is a highly advanced solid-state instrument, which measures the absolute position of a synchro transmitter. It provides both a user definable visual panel indication, and optional analog and digital signal outputs suitable for a variety of monitoring and control applications.

The 1250B may be programmed to perform mathematical scaling and offsetting of the rotational position of the synchro transmitter. A special feature of the 1250B is its capability to monitor up to 100 definable position segments. This is particularly suited to monitoring power transformer load tap changer position, where the desired readout is in whole tap numbers, and small discrepancies in position are masked. The display and all outputs follow a “stair step” function defined in the program when in this mode.

Another powerful feature of the 1250B is its ability to convert rotational position to a non-linear indication. A conversion table containing up to 100 data point pairs may be programmed. The 1250B will take a position reading, refer to the conversion table, and display the converted value. All outputs are driven from the displayed value. This feature makes the 1250B perfectly suited for applications like hydro dam gate position monitoring, in which a cable or tape winds onto a spool and the circumference grows with each revolution.

The 1250B may be wired in parallel with existing synchro transmitter/receiver pairs or wired directly to the synchro transmitter. Additional 1250Bs may be wired to the same transmitter without compromising the accuracy or reliability of the system.

## 1.0 INSTALLATION

- The Model 1250B is designed for use in any 50/60 Hz, five-wire synchro system compatible with electrical specifications given in Section 6.0 (Specifications). These devices include CX, TX, CDX, and TDX function synchros, as well as Self-Synchronous Indicator devices.
- The panel-mount case is designed to snap-fit into a **standard 1/8 DIN rectangular cut-out of 44mm (1.73 in.) by 92mm (3.62 in.)**
- Wiring is done to the rear of the case. #16 AWG (min.) type THHN, THWN, TFFN, or equivalent wire is recommended for the five AC synchro lines. #20 AWG (min.) shielded twisted pair wire is recommended for analog output wiring. Use appropriate spade lugs (provided) when connecting to the case terminals.
- Contact INCON Technical Service (207-571-1202) for application assistance if the synchro transmitter and the 1250B monitor are separated by a wire run of more than 1200 feet.

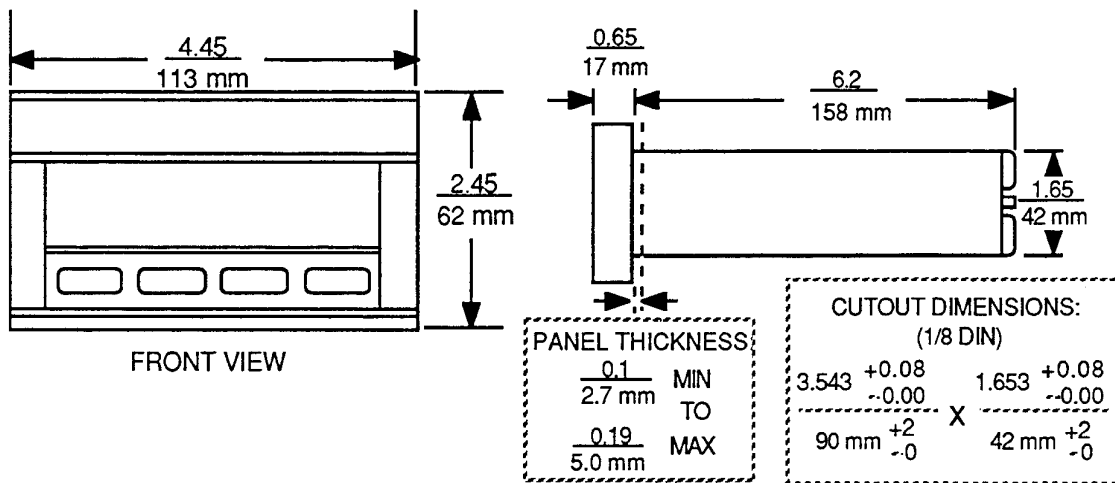

**Figure 1.1 Mechanical Dimensions**

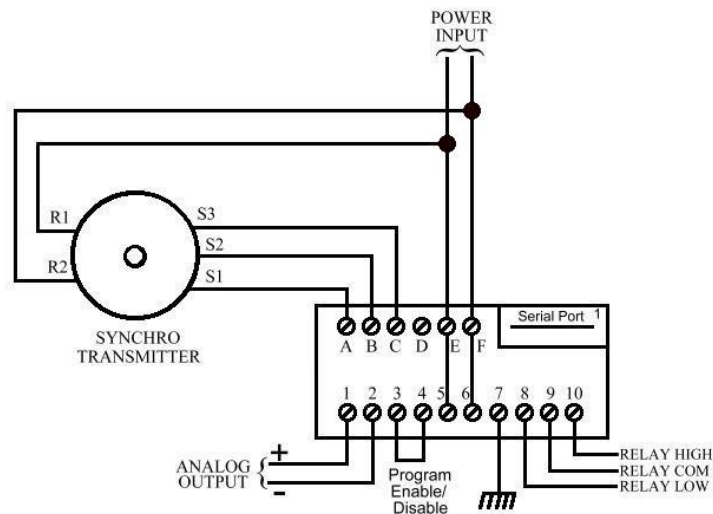

**Figure 1.2 Field Wiring Diagram**

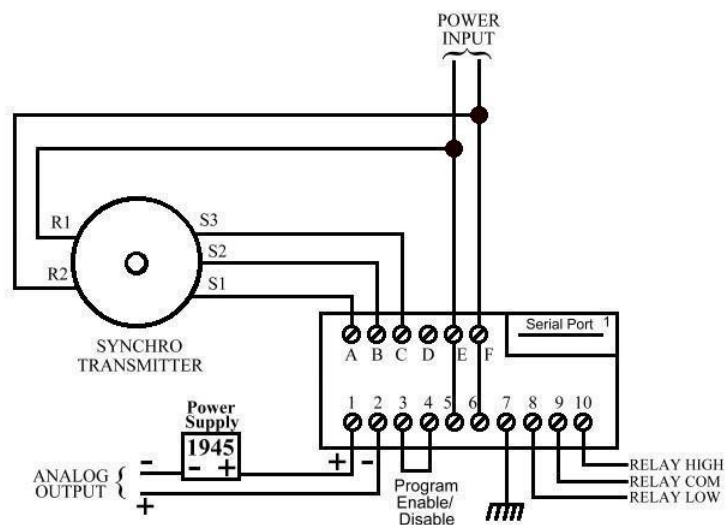

**Figure 1.3 Field Wiring Diagram with 4-20mA Output**

**Table 1.1 Terminal Functions**

<b>Terminal</b>	<b>Function</b>	<b>Terminal</b>	<b>Function</b>
A	S1	1	Analog Output +
B	S2	2	Analog Output –
C	S3	3	Program Mode Inhibit
D	(Spare)	4	Inhibit Return
E	R1 *	5	Line L1 *
F	R2 *	6	Line L2 *
		7	Chassis Ground
	* Terminals E & F are	8	Relay Low Contact N.O.
	jumpered to L1 & L2	9	Relay Common
	respectively	10	Relay High Contact N.O.

A DIP switch tells the firmware which hardware options are installed, so their function can be enabled. It is located on the top PCB, above the power transformer and is accessible through a slot in the left side of the case, towards the rear of the instrument.

**Table 1.2 DIP Switch Functions**

<b>Switch #</b>	<b>Function</b>
1	ASCII Communication Protocol Enable
2	MODBUS Communication Protocol Enable
3	Spare
4	High / Low Relay Limit Option Enable
5	Analog Output Option Enable
6	Spare
7	Spare
8	Spare

**Table 1.3 Digital Communication Connector Pin-Out**

1250B Pin#	DB-9 Pin#	RS-232 Function	RS-485 Comm Port Adapter Pin #	RS-485 Function
3	2	Transmit (O)	5	Data A(I/O)+
5	3	Receive (I)	4	Data B(I/O) -
7	N/C	RTS (Jumped to CTS)	3	Not Used
9	N/C	CTS (Jumped to RTS)	2	Not Used
13	5	Signal Gnd.	1	Signal Gnd.

**Installation Notes:**

- 1) A resistor may be wired remotely across the analog output terminals to convert analog output current to a voltage. Use Ohm’s Law to calculate the proper resistance for the desired voltage based upon the 1250B’s rated output current.
- 2) Maximum analog output load resistance: 0-1mA = 10K ohms; +/-1mA = 10K ohms; 0-2mA = 5K ohms; 4-20mA = (See Table 3.1).
- 3) Models with 4-20 mA analog output options must have an EXTERNAL LOOP POWER SOURCE of 10.0 VDC minimum, 24.0 VDC maximum, in series with the current loop. The INCON Model 1945 Power Supply is recommended for these installations. (See Figure 1.3).
- 4) When additional remote indication is needed, several 1250Bs may be wired in parallel to the same transmitter, or the INCON RD-4 Remote Indicator can be used.
- 5) The 1250B and the synchro transmitter MUST BE WIRED TO THE SAME AC SOURCE. Do not remove the jumpers from terminals E and F.
- 6) A provided jumper or keyswitch may be installed between terminals 3 & 4 to prevent the program from being changed. When these terminals are jumpered the menu will read “EP-x” instead of “OP-x”, which indicates that you can Examine each Parameter, but not change them.
- 7) After installation and programming, install the rear terminal guard with screws provided.
- 8) Analog outputs of 0-1mA, +/-1mA, and 0-2mA can be changed in the field to any one of the other two. Set the appropriate switches on Switch A and B per the table below. See Table 1.4 and Figure 1.4

**Table 1.4 Analog Output Switch Positions**

Model:	0	1	2
Switch A-1	OFF	ON	OFF
Switch A-2	OFF	OFF	OFF
Switch A-3	ON	OFF	OFF
Switch B-1	OFF	OFF	OFF
Switch B-2	ON	ON	ON
Switch B-3	ON	ON	ON

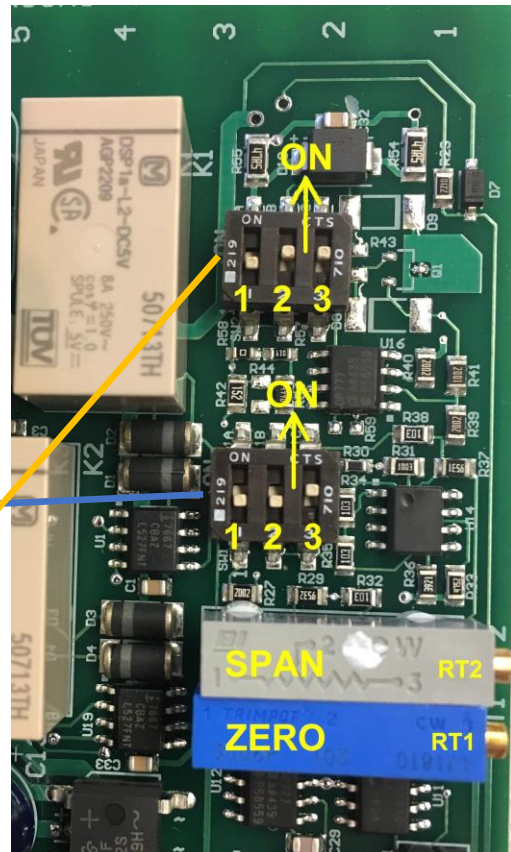

**Figure 1.4 Analog Switches & Trim-Pots**

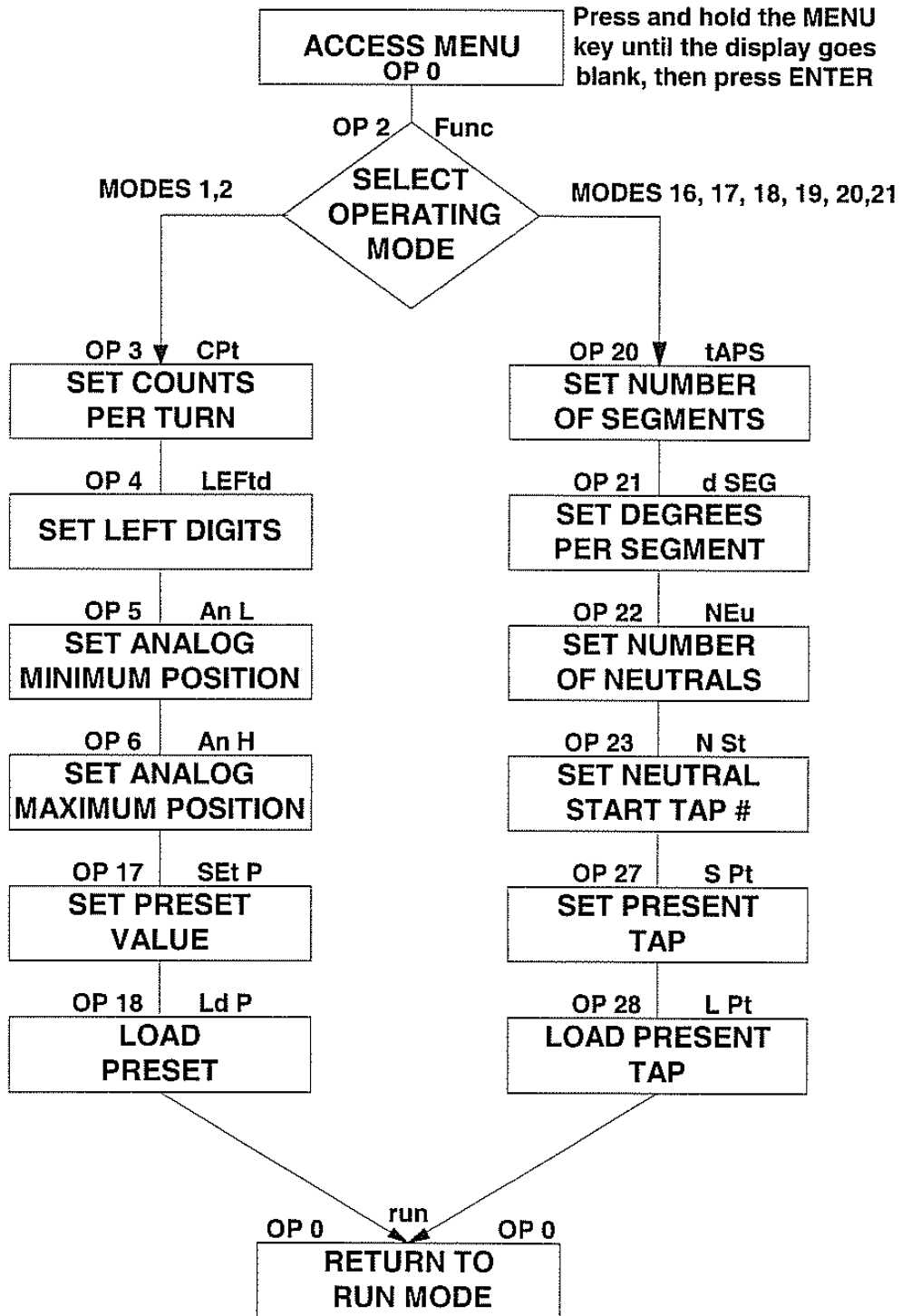

Figure 2.1 Simplified Programming Flowchart



## 2.0 PROGRAMMING

The Model 1250B has three methods of programming, numeric menu, alphanumeric menu, and serial port programming commands. Depending upon the serial port option ordered, the serial programming commands will be either RS-232 ASCII commands or RS-485 packet commands. (See Table 2.1 for a full listing of all programming menu items. See Figure 2.1 for a simple programming flowchart. See Table 2.2 for a full listing of all serial port programming commands and syntax.)

To access the numeric or alphanumeric programming menu, press the MENU key for several seconds until the display goes blank, then press the SELECT/ENTER key. The display should read “OP 0”. The default menu is the numeric menu. To choose the alphanumeric menu, press the DOWN key to select OP 99. Press the SELECT/ENTER key, the display should read “to OP”. Press the UP key. The display should read “run”. You are now in the alphanumeric menu mode.

To change a parameter using the numeric or alphanumeric menus, select the parameter to be changed from the menu, press the SELECT/ENTER key. The parameter’s present setting will now be displayed. You can change the setting by pressing the UP or DOWN key. To store the new setting, press the SELECT/ENTER key. The display will return to the menu.

**Table 2.1 Numeric and Alphanumeric Menu Items:**

Num- eric	Alpha-numeric Protocol	Default Value:	Programmable Range:	Function:
OP 0	Run			Press the SELECT/ENTER key to exit the Program mode
OP 1	rLY E	OFF	On or OFF	Enables the High/Low Relays
OP 2	Func	1	1, 2, 16, 17, 18, 19, 20, 21	Select Operating Mode (see page 12)
OP 3	CPt	360	-99999 to +99999	Scaled Mode: Counts per Turn
OP 4	LEFtd	4	0 to 5	Scaled Mode: Sets the number of digits to the <b>left</b> of the decimal point
OP 5	An L	0.0000	-99999 to +99999	Scaled Mode: Analog output low limit
OP 6	An H	360.00	-99999 to +99999	Scaled Mode: Analog output high limit
OP 7	rLY L	0.0000	-99999 to +99999	Scaled Mode: Relay Low limit
OP 8	rLY H	8.0000	-99999 to +99999	Scaled Mode: Relay High limit
OP 12	tnS F	0.0000	0.0000 to +3600.0	Rotation Rate Filter Threshold
OP 13	FLttH	0.0000	0.0000 to +99999	Averaging Filter Threshold
OP 14	FdPth	0.0000	0 to 128.00	Averaging Filter Depth
OP 17	SEt P	0.0000	-99999 to +99999	Scaled Mode: Set preset position
OP 18	Ld P		Ld	Scaled Mode: Loads preset position into memory
OP 19	CL P		CL	Scaled Mode: Clears position offset
OP 20	tAPS	33	2 to 100	Segmented Mode: Number of taps
OP 21	D SEG	10.000	-99999 to +99999	Segmented Mode: Degrees per tap
OP 22	NEu	1	0 to 9	Segmented Mode: Number of neutral taps
OP 23	N St	0-1	Any valid tap number	Segmented Mode: Sets neutral start tap
OP 24	rL Lt	-16	Any valid tap number	Segmented Mode: Sets low relay limit tap

<b>Num-eric</b>	<b>Alpha-numeric Protocol</b>	<b>Default Value:</b>	<b>Programmable Range:</b>	<b>Function:</b>
OP 25	rL Ht	+16	Any valid tap number	Segmented Mode: Sets high relay limit tap
OP 27	S Pt	0	Any valid tap number	Segmented Mode: Sets present tap position
OP 28	L Pt	0	Any valid tap number	Segmented Mode: Loads present tap position into memory
OP 29	dSPrL	OFF	On or OFF	Enables display of “r” or “L” in Function Modes 20 and 21
OP 30	CAL E	OFF	On or OFF	Enables analog output Calibration Mode
OP 31	L CAL		LO	Forces the analog output to its lowest signal output
OP 32	H CAL		HI	Forces the analog output to its high scale signal output
OP 33	d CAL		--	Forces the analog output to its mid scale signal outputs
OP 34	t CAL		LO then HI	Forces the analog output to alternate between high and low scale signal outputs
OP 40	LED t			Display LED Test: Turns on all LED’s
OP 41	RS t			RS-232 Echo Test: Re-transmits characters received through the RS-232 serial port
OP 42	InCAL		CAL	Calibrates synchro input circuitry
OP 43	RLY t		LO then HI	Relay Test: UP and DOWN keys toggle between LO and HI relays
OP 50	DSPbL	OFF	On or OFF	Causes the display to go blank after 60 sec.
OP 51	RS232	0	0 to 4, 6 and 7	RS-232 Mode: 0=Serial Disabled, 1=Data Logger Mode, 2=Polled Mode, 3=Sampled Mode, 4=Serial Command Mode, 5=Reserved, 6=RS485 MODBUS Mode, 7=Remote Display Driver Mode
OP 53	Aut25	OFF	On or OFF	Auto – Reset after “FA 25” Error (Page 13)
OP 60	Add		-99999 to +99999	Scaled Mode: Add a data point pair to the Non-Linear Conversion Table (Page 15)
OP 61	dEL		Select a data point pair from the N.L. Table	Scaled Mode: Delete a data point pair from the Non-Linear Conversion Table
OP 62	EdIt		Select a data point pair from the N.L. Table	Scaled Mode: Edit a data point pair in the Non-Linear Conversion Table
OP 63	dISP		Select a data point pair from the N.L. Table	Scaled Mode: Display a data point pair in the Non-Linear Conversion Table
OP 64	LEArn			Scaled Mode: Add a learned data point pair to the Non-Linear Conversion Table
OP 80	POrt	9600  8 n 1 128	2400, 4800, 9600, 14400, 19200, 28800,38400, 57600, 76800 7 or 8 n, E, O 1 or 2 1 to 255	Sets serial port parameters: (press the UP or Down key to select a value, press the enter key to advance to the next parameter) Baud rate Word length Parity (n=none, E=even, O=odd) Stop bits Address (for RS-485 Multi-drop)
OP 99	to OP	to OP		Toggles between Numeric and Alphanumeric menus

To prevent accidental or unwanted changes to the program parameters, a provided jumper may be installed across terminals 3 & 4. With this jumper installed, the numeric menu will read “EP *nn*” instead of “OP *nn*”. All parameters can be viewed but no changes can be made.

## 2.1 Serial Port Programming

To change a parameter using the RS-232 serial port programming commands, connect a computer terminal to the serial port cable. The terminal must have the proper Comm port settings to communicate to the 1250B (see section 3.3). See Table 2.2 for a full listing of all programming commands and syntax. At the command prompt, type a command followed by the new parameter setting, using proper syntax as shown in Table 2.2. Typing the command only, without a new parameter setting, will cause the 1250B to transmit the present setting for that parameter.

**Table 2.2 Serial Programming Commands:**

◇=space ↓=enter

Command Syntax:	Function:	Explanation:
SETUP↓	Enter the Setup Mode	This command must be entered before any other commands can be made.
EXIT↓	Re-starts the serial connection	Changes to comm. port settings will take effect
RUN↓	Return to the Run Mode	Changes to settings will take effect
DISP↓	Displays all setup parameters	Each setup command is displayed with the current parameter values following it
POS↓	Displays all current position data	Angle, turns count, linear position, non-linear position, tap position
RLYENA◇ON↓	Enables High/Low Relays	“ON” or “OFF” When enabled allows setting relay limits
MODE◇nn↓	Scaled or segmented modes	See page 14 for details
COUNTS◇nn.nnn↓	Set counts per turn	<i>n</i> = a floating-point number, 5 digits max.
LEFTDIG◇n↓	Set number of digits to the <u>left</u> of the decimal point	<i>n</i> = an integer from 0 to 5
ANAMIN◇nn.nnn↓	Set position value for minimum analog output	<i>n</i> = a floating-point number, 5 digits max
ANAMAX◇nn.nnn↓	Set position value for maximum analog output	<i>n</i> = a floating-point number, 5 digits max
RLYHIGH◇nn.nnn↓	Set high relay limit	<i>n</i> = a floating-point number, 5 digits max
RLYLOW◇nn.nnn↓	Set low relay limit	<i>n</i> = a floating-point number, 5 digits max
SETPRE◇nn.nnn↓	Set preset position value	<i>n</i> = a floating-point number, 5 digits max
TURNSF◇nn.nnn↓	Set Rotation Rate Filter Threshold (page 12)	<i>n</i> = a floating-point number, 5 digits max
FLTTH◇nn.nnn↓	Set Averaging Filter Threshold	<i>n</i> = a floating-point number, 5 digits max
FDPH◇nn.nnn↓	Set Averaging Filter Depth	<i>n</i> = a floating-point number from 0 to 128
LDPRE↓	Load preset pos. into memory	Must be done for SETPRE to take effect
CLRPRE↓	Clear preset	Cancels the effect of SETPRE
TADD◇x.xxxx◇yy.yyy↓	Add a data point pair to the Non-Linear Conversion Table	Will possibly re-number entries in the table (X=Degrees, Y= Conv. Value)
TDUMP↓	Displays all data point pairs in the N.L. Conversion Table	Each data point pair displayed is given a number

<b>Command Syntax:</b>	<b>Function:</b>	<b>Explanation:</b>
TEDIT $\diamond n \diamond x.xxxx$ $\diamond y.yyyy \downarrow$	Replace data point pair # <i>n</i> with a new data pair <i>x.xxxx,y.yyyy</i>	Will possibly re-number entries in the table (X=Degrees, Y= Conv. Value)
TDELETE $\diamond n \downarrow$	Delete data point pair # <i>n</i> from the N.L. Conversion Table	Will re-number entries in the table
TLEARN $\diamond yy.yyy \downarrow$	Add a learned a data point pair to the Non-Linear Conversion Table	Will possibly re-number entries in the table (Learned Degrees, Y= Conv. Value)
TAPS $\diamond nn \downarrow$	Set number of taps	<i>n</i> = an integer from 2 to 100
DEGSEG $\diamond n.nnnn \downarrow$	Set degrees per segment	<i>n</i> = a floating-point number, 5 digits max, average number of degrees between taps
NEUTRALS $\diamond n \downarrow$	Set number of neutral taps	<i>n</i> = an integer from 0 to 9
NSTART $\diamond nn \downarrow$	Set neutral start tap number	<i>n</i> = an integer, any valid tap number
RLYLT $\diamond nn \downarrow$	Set low relay tap number	<i>n</i> = an integer, any valid tap number
RLYHT $\diamond nn \downarrow$	Set high relay tap number	<i>n</i> = an integer, any valid tap number
SETTAP $\diamond nn \downarrow$	Set present tap position	<i>n</i> = an integer, any valid tap number
LDTAP $\downarrow$	Load present tap pos. into memory	Must be done for SETTAP to take effect
DISPRL $\diamond ON \downarrow$	Enables the display of “r” (raised) and “L” (lowered) tap numbers	“ON” or “OFF” When enabled causes the display to show “r” and “L” in function modes 20 and 21 only
ANACAL $\downarrow$	Enter analog calibration mode, the 1250 analog output will be forced to Low / Mid / High signal output	Press the space bar to toggle between Low / Mid / High analog output. Press the enter key to stop calibration
LEDTEST $\downarrow$	Turns on all display segments	Press the enter key to stop the LED test
RLYTEST $\downarrow$	Turns on one relay at a time for testing	Press the space bar to toggle between Low relay and High relay. Press Enter to Exit Test
INCAL $\downarrow$	Self-calibrates the input circuitry	Outputs “Pass” or “Fail” calibration result
DSPBL $\diamond ON \downarrow$	Enables the display blanking feature	“ON” or “OFF” When enabled causes the display to go blank after 60 sec.
AUTO25	Enables the automatic reset after an “FA25” error	“ON” or “OFF” When enabled, will automatically return to normal run mode after input signal returns to normal range
RESET25	Resets “FA25” Error	Manually resets the “FA25” error.
SERIAL $\diamond n \downarrow$	Set serial RS-232 communication mode	0=Serial Disabled, 1=Data Logger Mode, 2=Polled Mode, 3=Sampled Mode, 4=Serial Command Mode, 5= Reserved, 6=RS485 Mode, 7=Remote Display Driver
PORT $\diamond bbbb \diamond w \diamond p$ $\diamond s \diamond a \downarrow$	Set comm. port settings: baud rate, word length, parity, stop bits, and address	<i>b</i> = 2400, 4800, 9600, 14400, 19200, 28800, 38400, 57600, 76800 baud <i>w</i> = 7 or 8-bit word <i>p</i> = n, E, O <i>s</i> = 1 or 2 stop bits <i>a</i> = 0 to 255
PROGDIS	Displays Status of program disable input	0=Open 1=Closed
MENU $\diamond 1 \downarrow$	Set the menu type	“1” = Numeric menu or “2” = Alpha-numeric menu
HELP $\diamond (command) \downarrow$	Lists all available commands	All commands will be listed with syntax

## Synchro Noise Filtering

### Overview:

There are some applications where the 1250B may be installed in environments where harmonic noise on the power line can cause an unstable reading of the synchro position. Assuming that a stable, steady position reading is always better than a fluctuating reading, INCON has devised a solution to these problems. Two types of position filtering have been added to the 1250B's firmware – a Turns Rate Threshold Filter, and an Averaging Filter. The strength of each filter can be adjusted so that the best combination can be achieved for individual applications. The factory default programming is for both of these filters to be OFF.

### Description:

The **Turns Rate Threshold** filter allows a position measurement of the synchro to be accepted only if measurements of the synchro's output voltages indicate that the **synchro is rotating at a rate** of less than the programmed number of degrees per second (either clockwise or counter-clockwise). If a rotation rate faster than the programmed number of degrees per second is measured, the measurement is not acknowledged. It is assumed to be a noise-induced aberration and the display will freeze at the last known good reading. The nature of harmonic noise is that its high frequency will cause the synchro output signal to be randomly measured higher or lower than the true signal voltage. This would be interpreted as abrupt rotations of the **synchro** at a very high rotation rate. Therefore, this filter will be effective in cancelling the destabilizing effect of harmonic noise on the power line. The 1250B will display the synchro position more faithfully, but more importantly, the accidental accumulation of turns will be prevented.

This Turns Rate Threshold should be set at least TWICE the maximum expected synchro rotation rate in Degrees Per Second. If harmonic noise is present on the power line, the 1250B may not follow the normal synchro rotation. The display will be frozen in one position. In this case, increase the Turns Rate Threshold value significantly until a valid reading of the synchro is attained. The value may be adjusted up or down as needed to reach the desired filtering effect. Remember: a smaller Threshold value means a stronger filtering effect; a larger Threshold value means a less effective filter.

The **Averaging Filter** causes the displayed value to change more slowly, as a number of **measured position values are averaged**. With this filter activated, the effects of noise-induced aberrations are lessened, the position reading is very stable, but at the cost of a somewhat sluggish display. The displayed position may lag behind the actual synchro position by several seconds, depending upon the filter's settings. This filter is especially helpful in applications where a very stable, slow changing reading is required. A programmable **Averaging Filter Threshold** is available to disable the averaging during periods of faster rotation rates. When this Threshold is set to a number other than zero, the filter will stop averaging while the synchro is being turned faster than the programmed number of **display counts per second**. The filter will resume averaging when the rotation rate drops below the programmed number of display counts per second.

## Programming:

**OP 12 (tnS F)** sets the **Rotation Rate Threshold** for the first filter. If the synchro rotates slower than this number of **degrees per second**, the measured positions will be accepted as valid synchro positions, and immediately displayed. Synchro rotations faster than this rate will be ignored and assumed to be noise-induced aberrations. When **OP 12 (tnS F)** is set to zero, this filter will be disabled. The maximum value for this parameter is “3600.0”. The Serial Command Line protocol for this parameter is: “**TURNSF\_ nnn.nn**”

**OP 13 (FLtH)** sets the **Turns Rate Threshold** for the averaging filter. If the synchro rotates slower than this number of **display counts per second**, the second filter will be active and will average the position readings. Synchro turns faster than this rate will cause the filter to temporarily stop averaging. When **OP 13 (FLtH)** is set to zero, the averaging filter will be active at all times. The maximum value for this parameter is “99999”. Serial Command Line protocol for this parameter is: “**FLTTH\_ nnn.nn**”

**OP 14 (FdPtH)** sets the **Depth** of the averaging filter. The higher this number, the greater number of position samples will be averaged and the longer it will take for the display to be updated during a position change. When **OP 14 (FdPtH)** is set to zero, this filter will be disabled. The maximum value for this parameter is “128.0”. The Serial Command Line protocol for this parameter is “**FDPTH\_ nnn.nn**”.

## Loss of Synchro Signal “FA 25” Error Code Reset

The INCON model 1250B has Synchro Signal Loss detection firmware that freezes all outputs at their last known good positions, and displays an “FA 25” error code when the synchro signal is lost. The 1250B has an item in the programming menu which allows the “automatic reset” portion of this feature to be enabled or disabled.

## Programming:

In the programming menu, there will be an item: “**OP 53**”, or its Alpha-Numeric equivalent: “**AUt25**”. If this menu item is selected, the default value will be “**OFF**”, meaning that the error condition will not automatically reset (the MENU key will need to be pressed to manually reset the FA 25 error code). This may be changed to “**On**” by pressing the UP or DOWN key. With this menu item set to “**On**”, the error code will automatically reset as soon as the synchro signal is restored. Press the ENTER key to store the selected setting. The serial commands to program this function are “**AUTO25 ON**” and “**AUTO25 OFF**”.

**IMPORTANT NOTICE:** When the synchro signal is lost the 1250B will not detect if synchro rotation occurs. When the synchro signal is restored, **the 1250B may not be reading the correct position**. All outputs (Analog, Relays, Serial,) which are driven by the displayed value may also be incorrect.

### Operating Modes:

The model 1250B has eight operating modes. Each mode causes the 1250B to function differently. Certain modes will have advantages in certain applications. Determine which of the following operating modes is best suited to your application:

- 1 = Linear Scaled Mode
- 2 = Non-Linear Scaled Mode
- 16 = Base 1 Uni-polar Segmented Linear Analog
- 17 = Base 1 Uni-polar Segmented Stepped Analog
- 18 = Base 0 Uni-polar Segmented Linear Analog
- 19 = Base 0 Uni-polar Segmented Stepped Analog
- 20 = Bi-polar Segmented Linear Analog
- 21 = Bi-polar Segmented Stepped Analog

### Mode 1: Linear Scaled Mode

This mode is used when the desired display and corresponding analog output signal is continuously variable. The synchro transmitter could stop in any position and the 1250B must give a corresponding position reading. The analog output corresponds to the continuously variable position, between minimum and maximum limits. To select this operating mode, use the **OP 2, Func, MODE** command to change the value to "1".

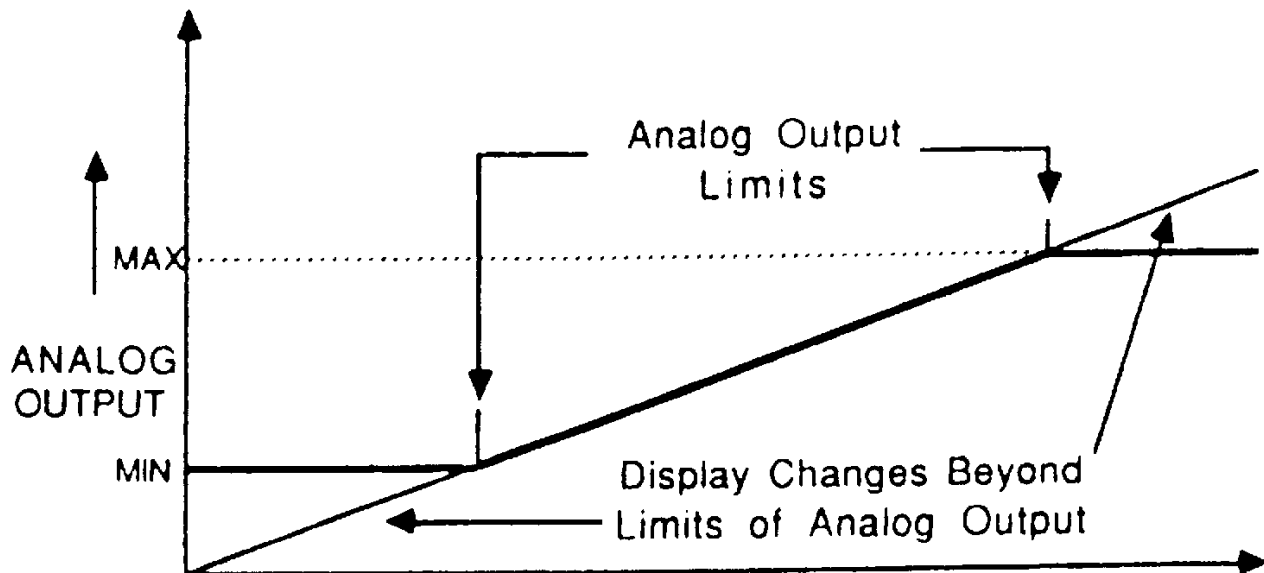

Figure 2.2 Linear Scaled Mode Analog Output

## Mode 2: Non-Linear Scaled Mode

The 1250B is capable of non-linear conversion / correction. Whenever there are two or more data point pairs in the conversion table the 1250B will automatically switch to non-linear scaled mode. Conversion table data point pairs may be added manually or “learned” automatically. To add a data point pair to the table, use menu item **OP 60, Add**. The first number entered ( $x$ ) represents the actual synchro position, based upon the Counts Per Turn programmed in OP 3 or CPt. The second number entered ( $y$ ) represents the converted position. Up to 100 data point pairs can be entered into the conversion table. Data point pairs can be entered through the serial command mode using the **TADD** command (see Table 2.2). To learn a data point pair, use menu **OP 64, LEarn**. Place the synchro transmitter in a known position. Enter the converted ( $y$ ) value for the present synchro position. Data point pairs can be learned through the serial command mode using the **TLEARN** command (see Table 2.2).

The analog output will span the minimum and maximum limits, just as it would in the linear scaled mode. The analog output will follow the non-linear, converted scale being displayed. To select this operating mode, use the **OP 2, Func, MODE** command to change the value to “2”.

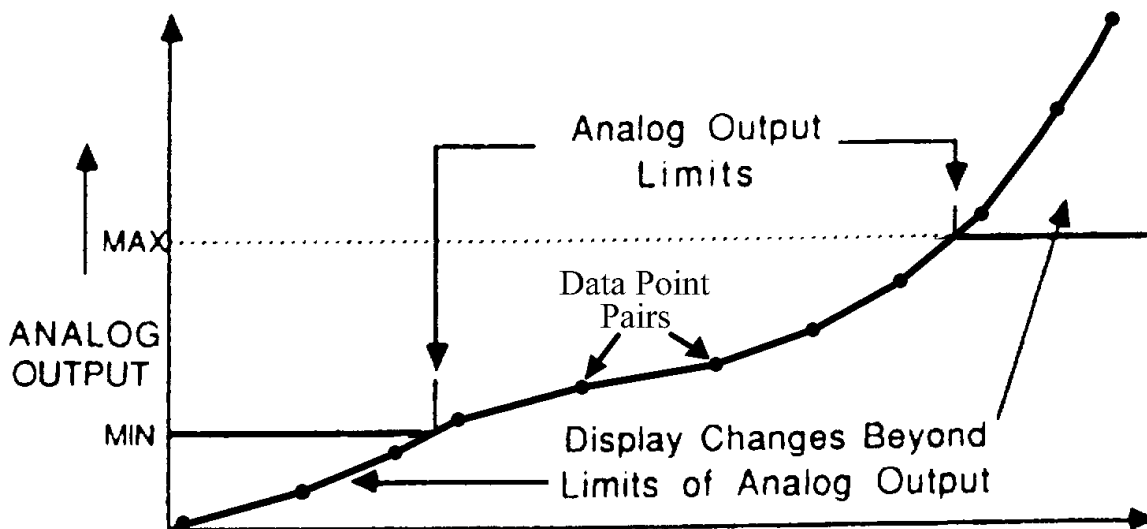
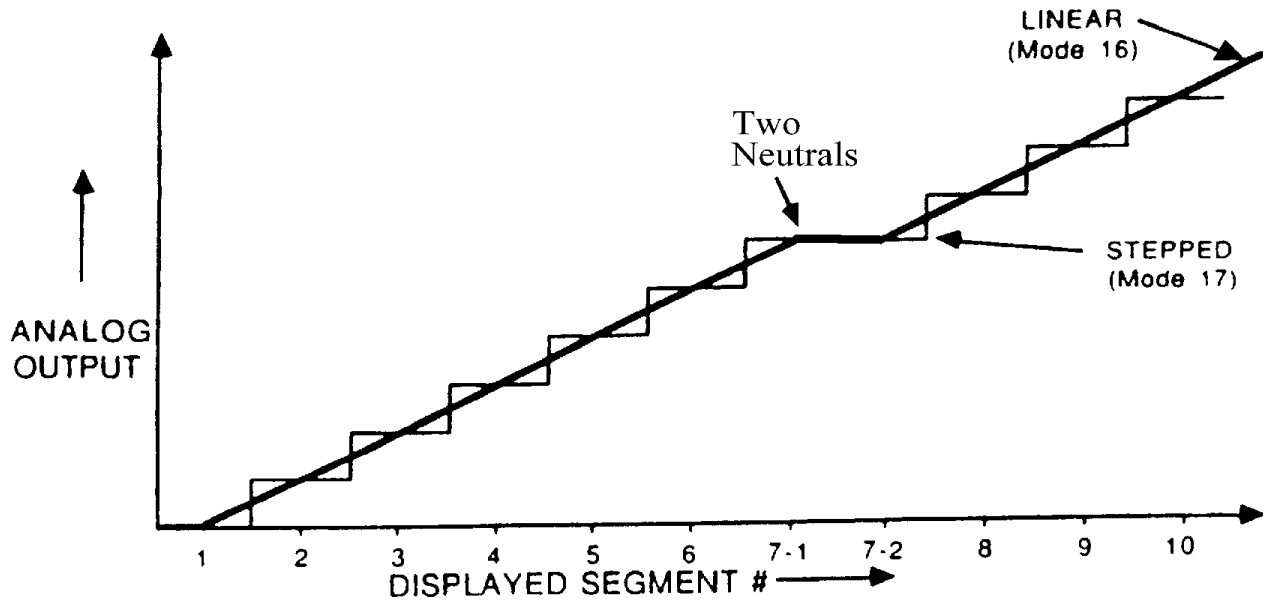

Figure 2.3 Non-linear Scaled Mode Analog Output



**Modes 16 & 17: Base 1 Uni-polar Segmented**

These modes are used for LTC monitoring when the lowest tap number is 1. There may be multiple neutral taps. They can be located anywhere between the lowest and highest taps as long as they are grouped together in one section. Mode 16 has a linear analog output that continuously varies with LTC shaft position. Mode 17 has a stepped analog output that jumps with each tap change. To select this operating mode, use the **OP 2, Func, MODE** command to change the value to “16” or “17”.



**Figure 2.4 Base 1 Uni-polar Mode Analog Output**

**Programming Example:**

A typical transformer Load Tap Changer application with taps numbered 1 to 32, 2 neutral taps (7-1 and 7-2), with 9.5° per tap, presently set on tap “18” would be programmed as follows:

OP 2 Operating mode = 17	OP 21 Degrees per tap = 9.5000	OP 27 Present tap = 18
OP 20 Number of taps = 33	OP 22 Number of neutrals = 2	OP 28 Load present tap
	OP 23 Neutral start tap = 7	

**Modes 18 & 19: Base 0 Uni-polar Segmented** These modes are used for LTC monitoring when the lowest tap number is 0. There may be multiple neutral taps, which can be located anywhere between the lowest and highest taps as long as they are grouped together in one section. Mode 18 has a linear analog output that continuously varies with LTC shaft position. Mode 19 has a stepped analog output that jumps with each tap change. To select this operating mode, use the **OP 2, Func, MODE** command to change the value to “18” or “19”.

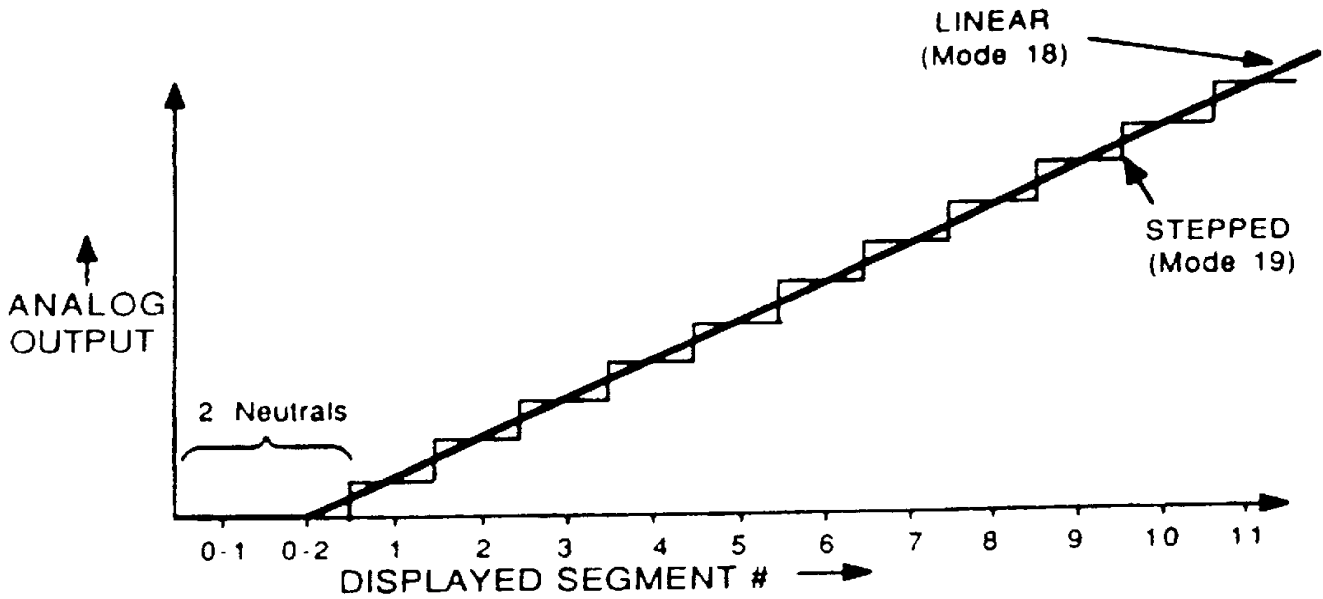

**Figure 2.5 Base 0 Uni-polar Mode Analog Output**

**Programming Example:**

A typical transformer Load Tap Changer application with taps numbered 0 to 16, 2 neutral taps, with 10.5° per tap, presently set on tap “9” would be programmed as follows:

OP 2 Operating mode = 19	OP 21 Degrees per tap = 10.500	OP 27 Present tap = 9
OP 20 Number of taps = 18	OP 22 Number of neutrals = 2	OP 28 Load present tap
	OP 23 Neutral start tap = 0	

**Modes 20 & 21: Bi-polar Segmented** These modes are used for LTC monitoring when the neutral tap(s) are in the center of the dial and there is an equal number of raised and lowered taps. There may be multiple neutral taps, which can be located anywhere between the lowest and highest taps as long as they are grouped together in one section. Mode 20 has a linear analog output that continuously varies with LTC shaft position. Mode 21 has a stepped analog output that jumps with each tap change. To select this operating mode, use the **OP 2, Func, MODE** command to change the value to “20” or “21”.

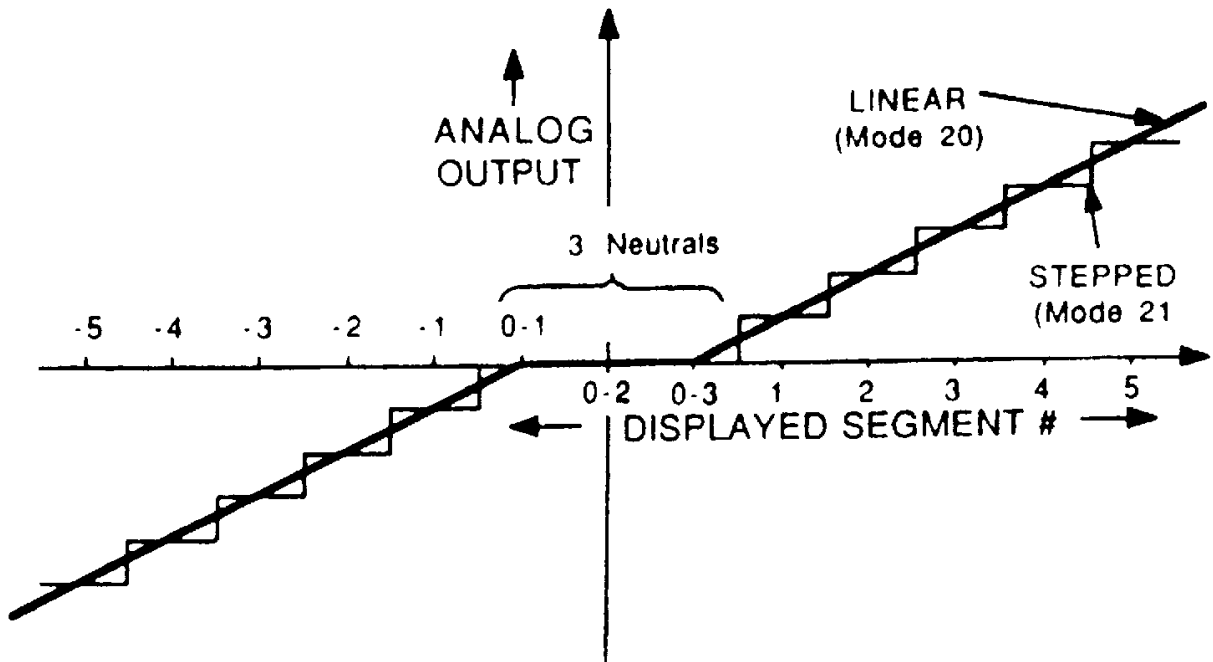

**Figure 2.6 Bi-polar Mode Analog Output**

**Programming Example:**

A typical transformer Load Tap Changer application with 16 raised and 16 lowered taps, 3 neutral taps located at 0, with 10° per tap, presently set on tap “2L” would be programmed as follows:

OP 2 Operating mode = 21	OP 21 Degrees per tap = 10.000	OP 27 Present tap = -2
OP 20 Number of taps = 35	OP 22 Number of neutrals = 3	OP 28 Load present tap
	OP 23 Neutral start tap = 0	

## Programming Notes:

If the Degrees Per Tap value is not known, the 1250B can be used to determine this value. Follow these steps to determine the Degrees Per Tap value:

- 1) Program the 1250B for Linear Scaled Mode as follows:

OP 2 Operating mode = 1	OP 3 Counts Per Turn = 360	OP 4 Left Digits = 3
-------------------------	----------------------------	----------------------

- 2) Return to the “run” mode. The 1250B should read a number with 1 decimal place.
- 3) Create a table with three columns, Tap Number, Degrees, and Difference, on a piece of paper.
- 4) Move the LTC to as many taps as possible. Record each tap number and the corresponding degree reading displayed on the 1250B in the table.
- 5) Subtract one degree reading from the next, for each tap, and write it in the Difference column in the table.
- 6) The differences should all be approximately the same. Take an average of the numbers in the Difference column. The result is the Degrees Per Tap number that the 1250B needs for the OP 21, D SEG, or DEGSEG command.
- 7) If there are differences that appear to be two, three or more times the normal difference between taps, these are “Double Taps” or “Multiple Taps”. Do not average these numbers with the rest when calculating the degrees per tap. If they occur at only one position, such as Neutral, then use the OP 22, NEu, NEUTRALS command to program the 1250B for more than one neutral.
- 8) If the multiple taps occur at more than one position, the Non-Linear mode must be used. Use the **OP 60, Add, TADD** or **OP 64, LEArn, TLEARN** commands to add the degree reading and tap number to the Non-Linear Conversion Table, as described on page 15. **A data point pair must be entered for EVERY tap.**

Programming for the Analog Output option is covered in Section 3.1.

Programming for the High/Low Relays option is covered in Section 3.2.

Programming for the Serial RS-232 Communication option is covered in Section 3.3.

Programming for the Serial RS-485 Communication option is covered in Section 3.4.

### 3.0 OPTIONS

The Model 1250B may be configured with one or more options. This section describes general use of each option, including wiring and programming for each option.

#### 3.1 Analog Output Option “-0”, “-1”, “-2”, “-4”,”

The analog output on the 1250B may be used to feed position information to a remote monitoring system such as SCADA, or a remote indicator such as the INCON model 1511-LTC. In the Scaled Modes, the span of the analog output must be programmed. In the Segmented Modes, the analog output automatically spans between the highest and lowest taps.

#### Wiring:

The 4-20mA analog output option must be wired with an external power supply of 10.0 to 24.0 volts DC in series with the analog output current loop (See Figure 1.3). The INCON Model 1945 is available for this purpose. All other analog output options are self-powered. Refer to Table 3.1 below for analog output load limits.

**Table 3.1 Analog Output Load Limits**

<b>Analog Output:</b>	<b>Load Minimum</b>	<b>Load Maximum</b>
0 to 1 mA	Zero Ohms	10K Ohms
+/- 1 mA	Zero Ohms	10K Ohms
0 to 2 mA	Zero Ohms	5K Ohms
4-20 mA	Zero Ohms	400 Ohms with 10 volt power supply
4-20 mA	Zero Ohms	1100 Ohms with 24 volt power supply

#### 3.1.1 Programming the Analog Output Span

The upper and lower limits of the analog output must be defined in the Scaled Modes. Use the **OP 5, An L, ANAMIN** command to set the lower limit of the analog output. Use the **OP 6, An H, ANAMAX** command to set the upper limit of the analog output. The analog output will span automatically between these two limits. The output will be at its minimum output when the displayed value is at the lower limit. The output will be at its maximum output when the displayed value is at the upper limit.

#### Note:

If the presence of high voltage AC “ripple” is found on the analog output terminals, it is generally not a problem with the 1250B itself. Check the isolation of all field wiring with respect to earth ground. All wiring should be completely isolated from ground. See section 3.2 Input Isolation Option. Contact INCON Technical Service for assistance if the problem persists.

#### 3.2 Input Isolation Option “-I”

The 1250B may be ordered with isolated input terminals. In cases where there is a compromise of the system isolation to earth ground, this option will prevent AC voltage from becoming impressed upon the analog output signal (See Note at the end of section 3.1). This option consists of two small signal isolation transformers installed in the signal input circuitry. Performance and reliability are not affected when this option is installed.

### 3.3 High / Low Relay Limits Option “-R”

The High / Low Relay Limits may be used as feedback in a control system or as an alarm when the position has exceeded desired limits. The high and low relays are normally open, dry contacts that do not latch when they are turned on. When the position value falls below the low relay limit, the low relay turns on. When the position value rises above the low relay limit, the low relay will turn off. When the value rises above the high relay limit the high relay turns on. When the value falls below the high relay limit, the high relay turns off.

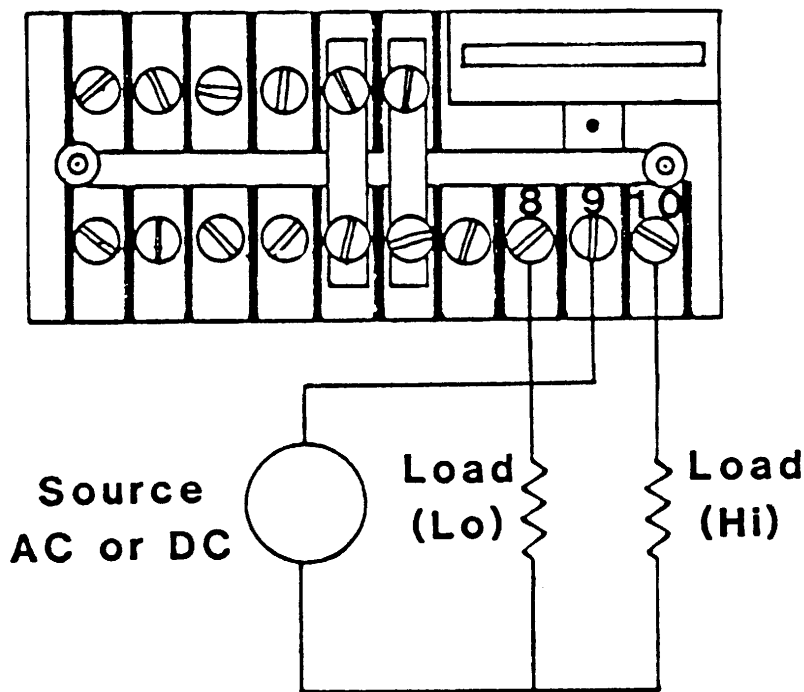

Figure 3.1 Relay Field Wiring Diagram

#### 3.3.1 Programming the Relay Limits

Before relay limits can be set, the relay option must be enabled in the menu. To do this use the **OP 1, rLY E, RLYENA** command to toggle the condition to “ON”. If this condition is left in the OFF state an error message “ERR 1” will appear when attempting to set relay limits.

If the 1250B is programmed for a Scaled Mode, use the **OP 7, rLY L, RLYLOW** command to set the Low Relay Limit and the **OP 8, rLY H, RLYHIGH** command to set the High Relay Limit.

If the 1250B is programmed for a Segmented Mode, use the **OP 24, rL Lt, RLYLT** command to set the Low Relay Limit and the **OP 25, rL Ht, RLYHT** command to set the High Relay Limit.

**DRAGHAND SIMULATION:** When the Relay Limits are not enabled, the 1250B will simulate mechanical Draghands. The Lowest position displacement can be viewed by pressing the DOWN key. The highest position displacement can be viewed by pressing the UP key. The Draghands may be individually reset by holding the UP or DOWN keys for 5 seconds. When the display reads “CL”, press the SELECT/ENTER key.

### 3.4 Serial RS-232

The Serial RS-232 (DCE) option on the Model 1250B can be used to program the instrument or to retrieve position data from the instrument. A Null Modem Adaptor is NOT needed with the provided Serial Cable.

There are seven operating modes for the serial RS-232 port:

Serial Disabled This mode stops all serial communication. To select this mode, use the **OP 51, RS232, SERIAL** command to choose mode “0”. If you are programming the instrument through the serial port, using the serial command mode, this “disabled” mode will not take effect until the commands “RUN” then “EXIT” are entered. The only way to de-select this “disabled” mode is to use the menu command **OP 51, RS232**, and select another mode.

Data Logger Mode This mode causes the 1250B to transmit the present position value on the display (including sign) once a second. To select this mode, use the **OP 51, RS232, SERIAL** command to choose mode “1”. If you are programming the instrument through the serial port, using the serial command mode, this mode will not take effect until the commands “RUN” then “EXIT” are entered.

Polled Mode When this mode is selected, the 1250B can be interrogated at any time via the RS-232 port for the current position. This is done by first instructing the 1250B to latch the current position by transmitting an asterisk (\*) to the unit. The position is then extracted, one character at a time, by transmitting the digits 0 through 6. Zero causes the sign character to be transmitted, 1 through 6 causes each position digit to be sent. The decimal point, wherever it may be positioned, is considered to be a digit. To select this mode, use the menu command **OP 51, RS232, SERIAL** command to choose mode “2”.

Sampled Mode When this mode is selected, the 1250B can be interrogated at any time via the RS-232 port for current position by transmitting a question mark (?) to the 1250B. When the 1250B receives a question mark, it responds by latching the current position and transmitting the value on the display in ASCII form. To select this mode, use the menu command **OP 51, RS232, SERIAL** command to chose mode “3”.

Serial Command Mode This mode enables programming the instrument through the serial port. To select this mode, use the menu command **OP 51, RS232** to choose mode “4”. When this mode is selected, no other serial communication can occur. In addition, if another Serial mode is chosen it will not be activated until the commands “RUN” then “EXIT” are given through the serial port command line.

MODBUS Mode When this mode is selected, the 1250B will respond to MODBUS commands via the serial port (RS-232 or RS-485). To select this mode, use the menu command **OP 51, RS232** command to choose mode “6”.

**Remote Display Driver Mode** This mode must be used when the 1250B is connected to a Model RD4 Remote Display. It causes the 1250B's RS-232 output to transmit the proper protocol and timing for the RD4 to mimic what is on the 1250B's display. To select this mode, use the menu command **OP 51, RS232** command to choose mode "7".

The communication port settings: baud rate, word length, parity, stop bits, and address are programmable using the **OP 80, Port, PORT** command. (See Table 2.1 and 2.2 for command protocol and choices.)

NOTE: When the port is programmed for 2 Stop Bits, the Parity must be "NONE".

**Table 3.2 Wiring: Digital Communication Connector Pin-Out**

1250B Pin#	DB-9 Pin#	RS-232 Function	RS-485 Comm Port Adapter Pin #	RS-485 Function
3	2	Transmit (O)	5	Data A(I/O) +
5	3	Receive (I)	4	Data B(I/O) -
7	N/C	RTS (Jumped to CTS)	3	Not Used
9	N/C	CTS (Jumped to RTS)	2	Not Used
13	5	Signal Gnd.	1	Signal Gnd.

### 3.5 Serial RS-485 Multi-Drop Option "-M"

The Serial RS-485 (**Half-Duplex**) option on the Model 1250B can be used to program the instrument and to retrieve position data from the instrument. The MODBUS protocol is a master/slave packet based protocol with the 1250B operating as a RTU slave. The MODBUS function commands recognized by the 1250B are "3" (read multiple registers) and "16" (write multiple registers). By supporting these two commands the 1250B is in level 0 compliance. Using these two commands it is possible to configure the 1250B as well as monitor it for current position. MODBUS RTU command and response packets are formatted as follows:

#### 3.5.1 RS-485 Packet Format - Read

Reading from Holding Registers:

**GAP** = A gap in transmission of 3.5 character frames indicates to the slaves that a new packet is to follow. No transmission gaps within a packet may exceed 1.5 character frames.

**Byte 1** = Device Address: Address 0 is a broadcast address that all units respond to regardless of programmed address. All other addresses can be programmed and used in this mode.

**Byte 2** = Function Code: When reading holding registers, this byte is "03h"



**Data Block** = Begins with the number of the first register (two bytes) in a command packet, or data from the first register (two bytes) in a response packet. Followed by the number of registers to be read (two bytes) in a command packet, or by data from subsequent registers.

**Last 2 Bytes** = Error Checking CRC – Lo Byte & Hi Byte

**Table 3.3 Read Registers Command Format**

GAP 3.5 Char Min.	Device Address	Function Code	# of First Register Hi	# of First Register Lo	# of Registers to Read Hi	# of Registers to Read Lo	CRC Lo	CRC Hi
		80h	03h	01h	03h	00h	04h	xx

**Table 3.4 Read Registers Response Format**

GAP 3.5 Char Min.	Device Address	Function Code	Byte Count	Data from First Register Hi	Data from First Register Lo	Data from Second Register Hi	Data from Second Register Lo
		80h	03h	08h	01h	03h	00h

		Data from Last Register Hi	Data from Last Register Lo	CRC Lo	CRC Hi
.....	.....	00h	02h	xx	xx

### 3.5.2 RS-485 Packet Format - Write

Write to Holding Registers:

**GAP** = A gap in transmission of 3.5 character frames indicates to the slaves that a new packet is to follow. No transmission gaps within a packet may exceed 1.5 character frames.

**Byte 1** = Device Address: Address 0 is a broadcast address that all units respond to regardless of programmed address. All other addresses can be programmed and used in this mode.

**Byte 2** = Function Code: When writing to holding registers, this byte is “10h”

**Data Block** = Begins with the number of the first register to be written (two bytes), followed by the number of registers to be written (two bytes), in either command or response packets. In a command packet the programming data for the first register will be the next two bytes followed by programming data for subsequent registers.

**Last 2 Bytes** = Error Checking CRC – Lo Byte & Hi Byte

**Table 3.5 Write Registers Command Format**

<b>GAP</b> 3.5 Char	Device Address	Function Code	# of First Register to be written to Hi	# of First Register to be written to Lo	# of Registers to Write Hi	# of Registers to Write Lo
Min.	80h	10h	10h	00h	00h	04h

Byte Count	Program Data for First Register Hi	Program Data for First Register Lo	Program Data for Second Register Hi	Program Data for Second Register Lo
08h	00h	01h	03h	60h

.....	.....	Program Data for Last Register Hi	Program Data for Last Register Lo	CRC Lo	CRC Hi
.....	.....	00	01	xx	xx

**Table 3.6 Write Registers Response Format**

<b>GAP</b> 3.5 Char	Device Address	Function Code	# of First Register to be written to Hi	# of First Register to be written to Lo	# of Registers to Write Hi	# of Registers to Write Lo	CRC Lo	CRC Hi
Min.	80h	10h	01h	00h	00h	04h	xx	xx

**3.5.3 RS-485 Packet Format – Error Exception Response**

When the master sends a command, the MSB bit in the Function Code is always clear. When a slave responds to the command, the slave leaves the MSB bit in the Function Code clear if the response is a normal response and sets MSB bit on if the response is an error exception response.

**GAP** = A gap in transmission of 3.5 character frames indicates to the slaves that a new packet is to follow.

**Byte 1** = Device Address: Address 0 is a broadcast address that all units respond to regardless of programmed address. All other addresses can be programmed and used in this mode.

**Byte 2** = Function Code: This byte will be the last command sent plus the MSB set on.

**Exception Code** = Illegal Command = 01  
Illegal Register = 02

**Last 2 Bytes** = Error Checking CRC – Lo Byte & Hi Byte

**Table 3.7 Error Exception Response Format**

<b>GAP</b> 3.5 Char	Device Address	Function Code	Exception Code	CRC Lo	CRC Hi
Min.	80h	90h	02	xx	xx

In the following Table 3.8, the meanings of the columns are as follows:

Register: MODBUS register address as seen in a MODBUS command beginning with register 40001 and ending with 49220. These addresses are in **decimal**.

Hex: The same register's address in **hexadecimal**, this value is calculated by subtracting 40001 from the register number. Thus register 40001 in decimal becomes 0000 in hex, and 40257 in decimal becomes 0100 in hex.

Function: Defines what each register contains or does when written. Some registers are read only and have no meaning when written. Others can be written or read. Others are write only special function and cause actions to be performed when they are written. Still others are "select registers", which select what other registers do when they are read or written. 45890 (1701h) is such a register, and selects which table position is affected by the other registers.

Format: This column defines what a register contains bit-by-bit in **binary**. A row of 16 symbols shows what each of the 16 bits of the register contain MSB first and LSB last. A BCD formatted floating point register is shown as follows (two 16 bit binary words):

Bcdabcbdbcdcbcd bcde000000vspppp

**bcd**a, **bcd**b, **bcd**c, **bcd**d, **bcd**e are each four-bit BCD digits, as it would be seen on a display.

**000000** are 6 unused bits that report as 0 when read and must be 0 when written.

**y** is an overflow bit that indicates that the number in the register is too big to display when it is a 1. 0 indicates a valid register value.

**s** is the sign bit and is 1 when the value in the register is negative. 0 indicates a positive number.

**pppp** is the position of the decimal point within the bcd digits.

Most registers are not as complex as a floating-point register.

An alternate floating-point format is supported and selected by writing a 1 to the 40256d (**00ff h**) register. This selects an IEEE floating-point format as follows (two 16 bit binary words):

seeeeeemmmmmmm mmmmmmmmmmmmmmmmm

The format of the IEEE floating-point number is as follows:

**s** is the sign bit,

**e** is the exponent bits, and

**m** are the mantissa bits.

**Table 3.8 RS-485 MODBUS Register Definitions**

<b>Register:</b>	<b>Hex:</b>	<b>Function:</b>	<b>Binary Format:</b>
40001 Read/Write	0000	setup / run mode select	000000000000000 <u>s</u> LSB ( <u>s</u> ) selects mode 0 – run mode 1 – setup mode (must be 1 before any program parameter can be changed)
40002 Read/Write	0001	synchro input signal status	000000000000000 <u>s</u> LSB ( <u>s</u> ) indicates status 0 – OK Input signal is present 1 – ALARM Input signal is lost
40256 Read/Write	00ff	select floating point format	00000000000000 <u>ff</u> LSBs ( <u>ff</u> ) selects format 00 – bcd floating-point format 01 –IEEE floating-point format
40257,40258 Read Only	0100,0101	angle	floating point number (bcd or IEEE): bcdabcbdbcdcbcd bcde000000vspppp
40259 Read Only	0102	turns count	<u>tttttttttttttt</u> 16 bits, number of turns
40260,40261 Read Only	0103,0104	linear position	bcdabcbdbcdcbcd bcde000000vspppp
40262,40263 Read Only	0105,0106	non-linear position	bcdabcbdbcdcbcd bcde000000vspppp
40264 Read Only	0107	tap, neutral	<u>ttttttt</u> 0000 <u>nnnn</u> “0000” are unused bits “ <u>t</u> ”= tap number “ <u>n</u> ”= neutral number
40513 Read/Write	0200	draghand reset control	00000000000000 <u>HL</u> bit = 1 to reset “ <u>H</u> ”= high draghand “ <u>L</u> ”= low draghand
40514, 40515 Read Only	0201,0202	peak draghand scaled mode	bcdabcbdbcdcbcd bcde000000vspppp
40516 Read Only	0203	peak draghand segmented mode	<u>ttttttt</u> 0000 <u>nnnn</u> “0000” are unused bits “ <u>t</u> ”= tap number “ <u>n</u> ”= neutral number
40517, 40518 Read Only	0204,0205	valley draghand scaled mode	bcdabcbdbcdcbcd bcde000000vspppp
40519 Read Only	0206	valley draghand segmented mode	<u>ttttttt</u> 0000 <u>nnnn</u> “0000” are unused bits “ <u>t</u> ”= tap number “ <u>n</u> ”= neutral number
40769 Read Only	0300	internal relay states	00000000000000 <u>HL</u> relay on, bit = 1 “ <u>H</u> ”= high relay “ <u>L</u> ”= low relay
41025 Read Only	0400	analog output	0000 <u>aaaaaaaaaaaa</u> 12 LSBs
44097 Read/Write	1000	operating mode	0000000000 <u>mmmmm</u> 5 LSBs (see list of modes on page 14)
44098, 44099 Read/Write	1001,1002	counts per turn	bcdabcbdbcdcbcd bcde000000vspppp
44100 Read/Write	1003	set digits left of the decimal point	000000000000 <u>LLL</u> 3 LSBs
44101, 44102 Read/Write	1004,1005	analog low limit	bcdabcbdbcdcbcd bcde000000vspppp

Register:	Hex:	Function:	Binary Format:
44103, 44104 Read/Write	1006,1007	analog high limit	bcdabcbdbcdcbcd bcde000000vspppp
44353 Read/Write	1100	number of taps	000000000 <u>nnnnnnn</u> 7 LSBs
44354, 44355 Read/Write	1101,1102	degrees per segment	bcdabcbdbcdcbcd bcde000000vspppp
44356 Read/Write	1103	number of neutrals	000000000000 <u>nnnn</u> 4 LSBs
44357 Read/Write	1104	neutral start segment	<u>ssssssssssssss</u> 16 bits, first neutral tap
44358 Read/Write	1105	display “r”&“L”	000000000000000 <u>d</u> enabled, LSB( <u>d</u> )= 1
44609 Read/Write	1200	relays enable	000000000000000 <u>r</u> enabled, LSB( <u>r</u> ) = 1
44610, 44611 Read/Write	1201,1202	relay low limit	bcdabcbdbcdcbcd bcde000000vspppp
44612, 44613 Read/Write	1203,1204	relay high limit	bcdabcbdbcdcbcd bcde000000vspppp
44614 Read/Write	1205	relay low tap	<u>ssssssssssssss</u> 16 bits, low tap limit
44615 Read/Write	1206	relay high tap	<u>ssssssssssssss</u> 16 bits, high tap limit
44616, 44617 Read/Write	1207, 1208	rotation rate filter threshold	bcdabcbdbcdcbcd bcde000000vspppp
44618, 44619 Read/Write	1209, 120A	averaging filter threshold	bcdabcbdbcdcbcd bcde000000vspppp
44620, 44621 Read/Write	120B, 120C	averaging filter depth	bcdabcbdbcdcbcd bcde000000vspppp
44865, 44866 Read/Write	1300,1301	preset position	bcdabcbdbcdcbcd bcde000000vspppp
44867 Read/Write	1302	preset tap	<u>ssssssssssssss</u> 16 bits, preset tap no.
44868 Read/Write	1303	load/clear preset control	0000000000000 <u>ccc</u> 3 LSBs ( <u>ccc</u> ) select 000 – no operation 001 – clear offset 010 – load preset
45121 Read/Write	1400	display blank	000000000000000 <u>b</u> enabled, LSB( <u>b</u> )=1
45122 Read/Write	1401	menu mode	000000000000000 <u>m</u> LSB ( <u>m</u> ) select 0= numeric, 1=alphanumeric
45123 Read/Write	1402	auto reset FA25	000000000000000 <u>m</u> LSB ( <u>m</u> ) select 0= Off, 1= On (Automatic Reset)
45633 Read/Write	1600	RS-232 mode	0000000000000 <u>rrr</u> 3 LSBs ( <u>rrr</u> ) select 000=datalogger mode, 001=polled mode, 010=sampled mode, 011=command, 100=reserved N/A, 101=RS485 Modbus,

Register:	Hex:	Function:	Binary Format:
			110=remote display driver
45634 Read/Write	1601	baud	000000000000 <b>bbbb</b> 4 LSBs ( <b>bbbb</b> ) 0000=300, 0001=1200, 0010=2400, 0011=4800, 0100=9600, 0101=14400, 0110=19200, 0111=28800, 1000=38400, 1001=57600, 1010=76800
45635 Read/Write	1602	word length	00000000000000 <b>w</b> LSB ( <b>w</b> ) select 0 = 7 bits, 1 = 8 bits
45636 Read/Write	1603	parity	00000000000000 <b>pp</b> 2 LSBs ( <b>pp</b> ) 00 = none, 01 = even, 10 = odd
45637 Read/Write	1604	stop bits	000000000000000 <b>s</b> LSB ( <b>s</b> ) select 0 = 1 bit, 1 = 2 bits
45638 Read/Write	1605	address	00000000 <b>aaaaaaaa</b> 8 LSBs ( <b>aaaaaaaa</b> )
45889 Read/Write	1700	table add/del/edit control	000000000000 <b>ccc</b> 3 LSBs ( <b>ccc</b> ) select 000 – no operation 001 – clear table 010 – add to table * 011 – load table position ** 100 – delete table position ** 101 – add learned table position *
45890 Read/Write	1701	table position	00000000 <b>tttttttt</b> 8 LSBs
45891, 45892 Read/Write	1702,1703	table x	bcdabcbdbcdcbdd bcde000000vspppp
45893, 45894 Read/Write	1704,1705	table y	bcdabcbdbcdcbdd bcde000000vspppp
45895 Read/Write	1706	table size	000000000 <b>sssssss</b> 7 LSBs
49217 Write Only	2400	LED test (write-only)	000000000000000 <b>s</b> LSB ( <b>s</b> ) select 0 = Off 1 = On (Test Display LED's)
49218 Write Only	2401	input calibration (write-only)	000000000000000 <b>s</b> LSB ( <b>s</b> ) select 0 = Off 1 = On (Perform Input Calibration)
49219 Write Only	2402	analog output calibration (write-only)	000000000000000 <b>s</b> LSB ( <b>s</b> ) select 0 = Off 1 = Low-Scale Output 2 = Mid-Scale Output 3 = High-Scale Output
49220 Write Only	2403	program disable input status (read-only)	000000000000000 <b>s</b> LSB ( <b>s</b> ) select 0 = Input is Open 1 = Input is Closed

\* To add or learn a new position in the table:

Step 1: First Command;

Write the X and Y values (Y only when learning a position) into registers 45891, 45892 (1702h, 1703h) and 45893, 45894 (1704h, 1705h) respectively.

Step 2: Second Command;

Write the “add to table” (010) command, or the “add learned table position” (101) command to register 45889 (1700h).

\*\* To read or delete a table position:

Step 1: First command;

Write the table position number of the position you wish to read or delete to register 45890 (1701h). (Table positions are numbered starting at 0 for the position with the lowest X value. When a position is added or deleted from the table the table positions are re-numbered.)

Step 2: Second command;

**To delete** the position from the table, write the “delete table position” (100) command to register 45889 (1700h). – Done –

**To read** the table position data point pair, write the “load table position” (011) command to register 45889 (1700h).

Step 3: Third command;

**To read** the table position data point pair, read the contents of registers 45891, 45892 (1702h, 1703h) for X and 45893, 45894 (1704h, 1705h) for Y.

## 4.0 Field Calibration and Test

**Calibration:** The Model 1250B should not require field calibration. However, there are provisions in the menu to facilitate Analog Output Calibration. The analog output may be adjusted in the field. A calibrated multi-meter should be used to measure the output signal during calibration.

To enable analog calibration, select the **OP 30, CAL** menu command and choose the “On” mode. If you are using the RS-232 serial port, use the **ANACAL** command. The analog output may be forced to LOW, MID, and HIGH output signal states.

If menu commands are being used, select the **OP 31, L CAL** command to force the analog output to LOW scale output. If you are using the RS-232 serial port, press the space bar on the computer terminal. This toggles the output between LOW, MID, and HIGH outputs. The display on the 1250B should read “LO”. The analog output low scale may now be adjusted by turning the “ZERO” pot, accessible through the slot in the right side of the case (see Figure 4.1), until the output signal is reading properly on the multi-meter.

If menu commands are being used, select the **OP 32, H CAL** command to force the analog output to HIGH scale output. If you are using the RS-232 serial port, press the space bar on the computer terminal. The display on the 1250B should read “HI”. The analog output high scale may now be adjusted by turning the “SPAN” pot (see Figure 4.1) until the output signal is reading properly on the multi-meter. Repeat analog LOW and HIGH calibration steps several times to assure proper output signal calibration of both. Some interaction may occur between the ZERO and SPAN adjustments.

If menu commands are being used, select the **OP 33, D CAL** command to force the analog output to MID scale output. If you are using the RS-232 serial port, press the space bar on the computer terminal. The display on the 1250B should read “--”. The analog output should read a mid-scale signal on the multi-meter. There is no adjustment for this mid-scale output.

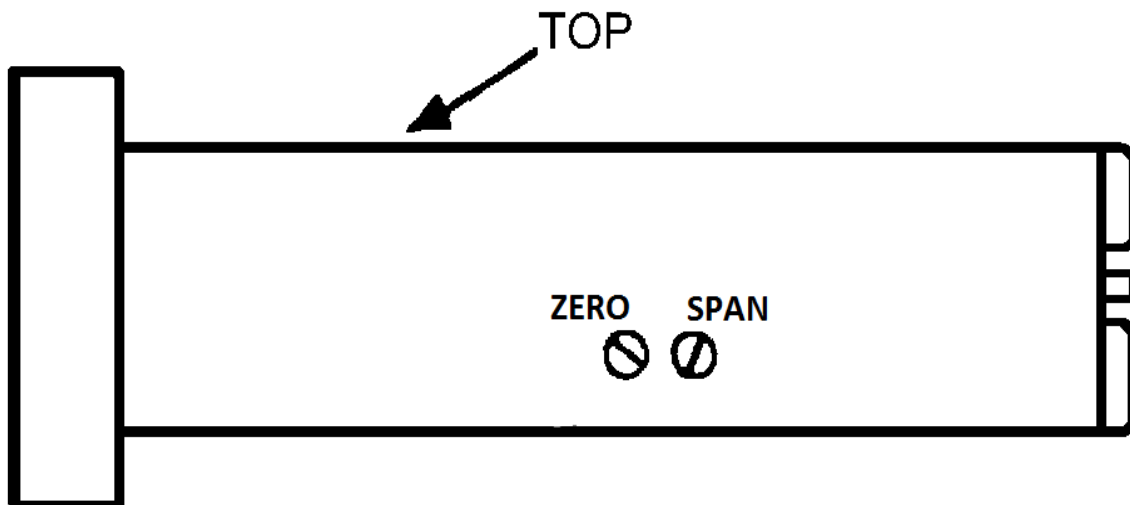

**Figure 4.1 Analog Output Adjustment Pots**



**Self-Diagnostic Tests:** The Model 1250B regularly performs several self-check diagnostic tests and generates error codes in the form “FA *n*” and “ERR *n*” if it detects an internal fault. The “*n*” number indicates the type of failure detected. See Section 5.0 for a full list of error codes and their explanation.

**Power Fail:** The 1250B is designed to shut its microprocessor off when it detects the line voltage falling below a fixed threshold, typically 85 to 105 VAC. This feature enables the microprocessor to properly store its data before the power is lost completely. The 1250B will automatically re-start itself when the line voltage rises above the Power Fail Threshold voltage.

**Firmware Revision:** The revision number can be displayed by pressing the “SELECT/ENTER” key while turning on the power to the 1250B.

**Cold Boot:** The 1250B has the capability to delete all user-programmed values and restore all factory default program values. This “cold boot” is accomplished by pressing the “MENU” key while turning on the power to the 1250B. There is no way to undo the effects of a cold boot.

**LED Test:** The display can be tested. Use the **OP 40, LED t, LEDTEST** command to turn on all display LED’s. Press the ENTER key to stop the test.

**RS-232 Port Test:** The RS-232 serial port can be tested. Use the **OP 41, RS t** menu command to enter the RS-232 Echo Test mode. With a computer terminal connected to the serial port, type in some characters. The 1250B should receive these characters and re-transmit them back to the terminal. The characters typed should appear on the terminal display. Press the ENTER key to stop the test.

**Relay Test:** The High / Low relays can be tested. Use the **OP 43, RLY t, RLYTEST** command to turn on one of the relays. The UP and DOWN keys will cause the 1250B to toggle between the High and Low relay. If you are using the RS-232 serial port, press the space bar on the computer terminal to toggle between the High and Low relay.

## 5.0 Error Codes

**Table 5.1 Error Codes**

<b>DISPLAY</b>	<b>DESCRIPTION</b>
<b>FA 2</b>	Watchdog Re-start (Processor Crash) If the condition recurs, call Technical Service.
<b>FA 3</b>	Memory Error at start-up (User programming is erased; Factory program defaults are re-loaded)
<b>FA 5</b>	Keyboard Error at Start Up (Up or Down Key, or more than one key is being pressed during Power-Up)
<b>FA 20</b>	Input Calibration Error (Input signal differential too large)
<b>FA 25</b>	Synchro input signal not present
<b>Err 5</b>	Analog minimum position cannot be displayed with the number of left digits set. (Increase number of left digits in OP 4)
<b>Err 6</b>	Analog maximum position cannot be displayed with the number of left digits set. (Increase number of left digits in OP 4) <u>OR</u> greater than 65,535 turns required to span Analog Min. to Analog Max. (Increase counts per turn (OP 3) or reduce analog output span.)
<b>Err 7</b>	Low Relay limit position cannot be displayed with the number of left digits set. (Increase number of left digits in OP 4)
<b>Err 8</b>	High Relay limit position cannot be displayed with the number of left digits set. (Increase number of left digits in OP 4) <u>OR</u> limit not useable, greater than 65,535 turns required to span between LO & HI relay limits (Increase counts per turn (OP 3) or reduce span between relay limits)
<b>Err 17</b>	Preset position cannot be displayed with the number of left digits set. (Increase number of left digits in OP 4) <u>OR</u> greater than 65,535 turns required to reach Analog Min. or Analog Max. from present position (increase counts per turn (OP 3) or reduce analog output span.)
<b>Err 30</b>	Analog output calibration mode not enabled (Change OP 30 to "On")
<b>Err 80</b>	Wrong combination of serial port settings (Check parity, data & stop bits)
<b>TAb d</b>	Non-Linear Table duplicate data point entered
<b>TAb E</b>	Non-Linear Table emptied
<b>TAb F</b>	Non-Linear Table full (100 data point pairs max.)
<b>Flashing 9's</b>	Display over-range (Increase number of left digits in OP 4)

## 6.0 Specifications

(All values are typical, unless otherwise specified)

ENCLOSURE:	RECTANGULAR PANEL MOUNTED METER
MATERIAL	PLASTIC
SIZE	89mm W X 41.3mm H X 178mm D
BEZEL	112mm W X 62mm h X 17.5mm D
MOUNTING	INTEGRAL SNAP-IN TABS
POWER INPUT:	
CONNECTOR	SCREW TERMINALS L1, L2, GND
VOLTAGE	115 VAC +/- 10%
FREQUENCY	47 TO 63 Hz
POWER CONSUMPTION	8 VA MAX
FUSE	INTERNAL (.375 AMP)
ISOLATION	TRANSFORMER (1000 VAC)
TEMPERATURE RANGE	
OPERATING	0 TO 55 DEG. C
DISPLAY	5-DIGIT, 7 SEGMENT LED WITH SIGN, RED
HEIGHT	0.56 INCHES
STATUS INDICATION	FOUR DISCRETE LED'S, RED
VIEWING DISTANCE	23 FEET
UPDATE RATE	10 TIMES PER SECOND
DISPLAY RANGE	0.0000 TO 99999.
	SCALABLE TO OTHER UNITS
ACCURACY (25 DEG. C)	+/- 10 ARC MINUTES W/ TYPICAL SYNCHRO
RESOLUTION	6 ARC MINUTES
TEMPERATURE DRIFT	+/- 0.2 ARC MINUTES PER DEGREE C WITH TYPICAL SYNCHRO
ELECTRICAL INPUTS	
SIGNAL INPUT	3 PHASE, 0 TO 90 VAC (INPUT ISOLATION OPTIONAL)
PROGRAM DISABLE	CONNECT TERMINAL #3 TO #4
ELECTRICAL OUTOUTS	
OPTIONAL HI/LO RELAYS	2 ea. FORM 1A N.O. 3A @ 250 VAC (RESISTIVE) 1/10 HP @ 250VAC 3A @ 30 VDC (RESISTIVE)
TOTAL ISOLATION	1000 VAC
ANALOG OUTPUT	
RESOLUTION	12 BITS (+/- 0.025%)
NON-LINEARITY	+/-0.1% OF FULL SCALE



**Model 1250B**

**Installation & Programming Manual**

---